

Installation Instructions

0-100% Downflow Dry Bulb Economizer

Model Number: BAYECON089A, BAYECON090A
Used With: TCD/YCD150F, TCD/YCD155F, 175F, 180F, 200F, 210F, 240F, 250F, 300F, TCD/YCD151E, 181E, 211E, 241E, 301E, WCD150E, 155E, 180E, 200E, 240E

SAFETY WARNING

Only qualified personnel should install and service the equipment. The installation, starting up, and servicing of heating, ventilating, and air-conditioning equipment can be hazardous and requires specific knowledge and training. Improperly installed, adjusted or altered equipment by an unqualified person could result in death or serious injury. When working on the equipment, observe all precautions in the literature and on the tags, stickers, and labels that are attached to the equipment.

May 2011

© 2011 Trane
All rights reserved

ACC-SVN78D-EN

1 Cautions, Warnings and Notices

WARNING

Indicates a potentially hazardous situation which, if not avoided, could result in death or serious injury

CAUTION

Indicates a potentially hazardous situation which, if not avoided, could result in minor or moderate injury. It may also be used to alert against unsafe practices.

NOTICE

Indicates a situation that could result in equipment or property-damage only accidents.

Important: Environmental Concerns! Scientific research has shown that certain man-made chemicals can affect the earth's naturally occurring stratospheric ozone layer when released to the atmosphere. In particular, several of the identified chemicals that may affect the ozone layer are refrigerants that contain Chlorine, Fluorine and Carbon (CFCs) and those containing Hydrogen, Chlorine, Fluorine and Carbon (HCFCs). Not all refrigerants containing these compounds have the same potential impact to the environment. Trane advocates the responsible handling of all refrigerants-including industry replacements for CFCs such as HCFCs and HFCs.

Important: Responsible Refrigerant Practices! Trane believes that responsible refrigerant practices are important to the environment, our customers, and the air conditioning industry. All technicians who handle refrigerants must be certified. The Federal Clean Air Act (Section 608) sets forth the requirements for handling, reclaiming, recovering and recycling of certain refrigerants and the equipment that is used in these service procedures. In addition, some states or municipalities may have additional requirements that must also be adhered to for responsible management of refrigerants. Know the applicable laws and follow them.

2 WARNING

Personal Protective Equipment Required!

Installing/servicing this unit could result in exposure to electrical, mechanical and chemical hazards. Before installing/servicing this unit, technicians MUST put on all Personal Protective Equipment (PPE) recommended for the work being undertaken. ALWAYS refer to appropriate MSDS sheets and OSHA guidelines for proper PPE. When working with or around hazardous chemicals, ALWAYS refer to the appropriate MSDS sheets and OSHA guidelines for information on allowable personal exposure levels, proper respiratory protection and handling recommendations. If there is a risk of arc or flash, technicians MUST put on all necessary Personal Protective Equipment (PPE) in accordance with NFPA70E for arc/flash protection PRIOR to servicing the unit. Failure to follow recommendations could result in death or serious injury.

Inspection & Parts

Inspection

1. Unpack all components of the kit.
2. Check carefully for any shipping damage. If any damage is found it must be reported immediately and a claim made against the transportation company.
3. Visually inspect the components for shipping damage as soon as possible after delivery, before it is stored. Concealed damage must be reported within 15 days.
4. If concealed damage is discovered, stop unpacking the shipment.
5. Do not remove damaged material from the receiving location. Take photos of the damage, if possible. The owner must provide reasonable evidence that the damage did not occur after delivery.
6. Notify the carrier's terminal of damage immediately by phone and by mail. Request an immediate joint inspection of the damage by the carrier and the consignee.

Note: Do not attempt to repair any damaged parts until the parts are inspected by the carrier's representative.

3 Field Installed Economizer

Each economizer ships partially assembled. The steps for installation are illustrated throughout this guide. Refer to the illustrations as the steps are performed. Figure 1 illustrates the major components of the economizer when shipped for field installation.

Figure 1. Major economizer components

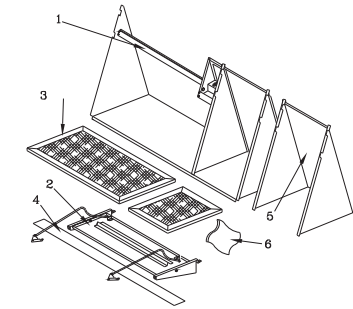

Parts List

As the economizer is un-crated, locate the following parts:

1. Outside air damper assembly (with wire harness)
 2. Return air damper assembly
 3. 2 Mist eliminators
 4. 1 Block-off,
 5. Barometric relief hood
 6. Plastic bag of miscellaneous parts:
 - a. Screws
 - b. Supply air temperature sensor
 - c. 1 Tube of sealant
 - d. 1 Edge protector
 - e. Installation and operation manual
 - f. rubber grommet
- Verify that all of the parts are available for installation.

4 Installation

WARNING

Hazardous Service Procedures!

The procedures recommended in this section of the manual could result in exposure to electrical, mechanical or other potential safety hazards. Always refer to the safety warnings provided throughout this manual concerning these procedures. When possible, disconnect all electrical power including remote disconnect and discharge all energy storing devices such as capacitors before servicing. Follow proper lockout/tagout procedures to ensure the power can not be inadvertently energized. When necessary to work with live electrical components, have a qualified licensed electrician or other individual who has been trained in handling live electrical components perform these tasks. Failure to follow all of the recommended safety warnings provided could result in death or serious injury.

WARNING

Proper Field Wiring and Grounding Required!

All field wiring MUST be performed by qualified personnel. Improperly installed and grounded field wiring poses FIRE and ELECTROCUTION hazards. To avoid these hazards, you MUST follow requirements for field wiring installation and grounding as described in NEC and your local/state electrical codes. Failure to follow code could result in death or serious injury.

1. Remove the filter/fan compartment access panel.
2. Remove the unit end panel (evaporator end).
3. Place the return air damper assembly into the return air opening as illustrated in Figure 2. Insure the damper is positioned with the sheet metal lip in the upward position.
4. Attach the pivotal brackets to the unit using 2 screws per bracket, as illustrated in Figure 2.
5. Raise the damper and rods into the vertical position. Tie the damper rods to the filter rack to prevent them from interfering with the positioning of the economizer as illustrated in Figure 2.

6. Insure damper is positioned with sheet metal lip in the upward position, as illustrated in Figure 2.

Figure 2. Damper, rod assembly and positions

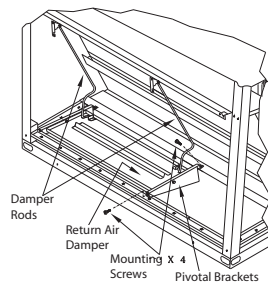

7. Attach the barometric relief hood to the back of the economizer assembly, using 2 screws at the top, as illustrated in Figure 3.

Figure 3. Relief hood/economizer assembly

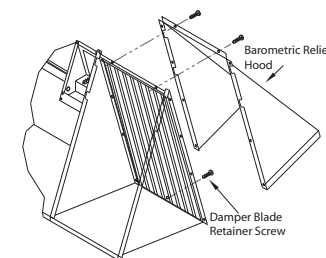

Note: If barometric relief is desired, remove the shipping screw that holds the barometric relief damper blade and ensure that the damper swings freely, before attaching the barometric hood.

8. Install the block-off as illustrated in Figure 4. The block-off is designed to close the opening created, between the economizer and the base, when the economizer assembly is in its operating position.

6. Holding the block-off with the holes at the bottom and the bottom angle outward press the bottom of the block-off against the unit and line up the holes. Using the provided screws, secure it into place.
9. Remove approximately 3" of gasket material from the bottom of each corner post to expose the holes used to attach the economizer assembly to the unit, as illustrated in Figure 4, detail "A".

Note: There are two holes, a (large) clearance hole and a (small) engagement hole. The usage of each hole will be discussed as the process continues.

Figure 4. Block-off installation

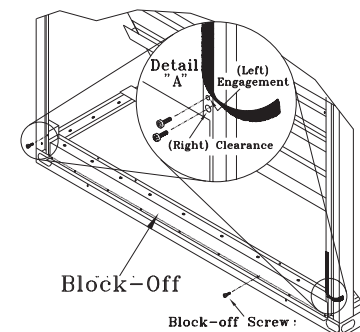

10. With the barometric relief hood attached to the economizer assembly, place the assembly into the opening with the back right flange, on the economizer, behind the corner post flange, as illustrated in Figure 5. Position the left side flange, on the economizer, in front of the corner post flange.

With the screws provided, secure the bottom right hand side of the economizer assembly by inserting the screws, through the clearance holes in the corner post, into the engagement holes in the economizer assembly, as illustrated in Figure 5, detail "A".

Secure the bottom left hand side of the economizer assembly by inserting the screws, through the clearance holes in the economizer assembly, into the engagement holes of the corner post. Refer to Figure 5, detail "A".

7. Assembly placement

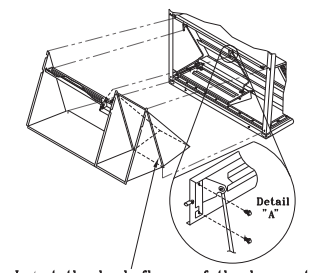

Insert the back flange of the barometric damper behind the right cornerpost.

11. Before the right hand return air linkage bracket can be installed, two (2) outside air damper screws must be removed as illustrated in Figure 5, detail "A". Align the return air linkage bracket with these holes and reinstall the two (2) screws. Install the left hand return air linkage bracket using the engagement holes in the outside air damper.
12. Manually operate the dampers, slowly, to ensure no binding exists.

Figure 6. Rubber grommet placement

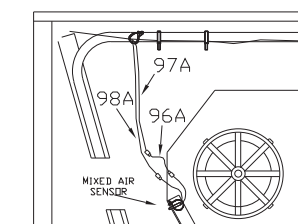

13. Install the rubber grommet, provided with the sensor, into the hole on the fan assembly channel, as illustrated in Figure 6.
14. Insert the supply air temperature sensor through the grommet, approximately one half (1/2) inch, with the end pointing toward the coil, as illustrated in Figure 6.

15. Locate wires 97A and 98A. Wire 96A will be wire tied to them. Connect Mixed Air Sensor to wiring. See [Figure 6](#).

Important: When unit is equipped with a TCI (Communication Interface), the supply air sensor must be located downstream of the heat source for a true reading, and to utilize the "supply air tempering" feature. This requirement also applies when the unit is used with any Integrated Comfort™ System (ICS) device such as Tracer®, Tracer®, or ComforTrac™.

16. Install the mist eliminators with the directional arrow pointing up. Loosen the screws holding the mist eliminator angles and adjust them to hold the mist eliminators in position. Tighten the screws.

Note: Ensure the directional arrow on the mist eliminator is pointing in the same direction as the airflow.

Wiring Connections

Locate unit wiring harness plug P8 (wires 55, 54, 56, 57) located at the end of the wiring raceway in the return air section. Plug P8 into J7 on the economizer actuator motor.

Locate unit wiring harness plug P13 (wires 97A & 98A) located at the end of the wiring raceway in the return air section. Plug P13 into J13 (MAT) on the economizer actuator motor. See [Figure 7](#).

Figure 7. RTEM terminal identifications

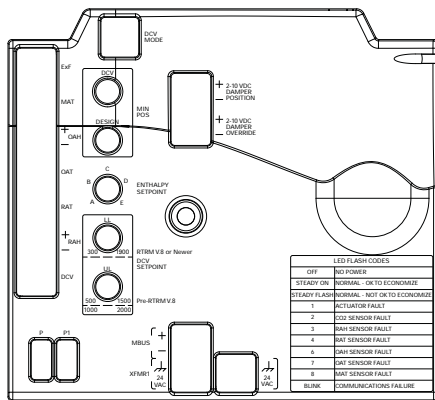
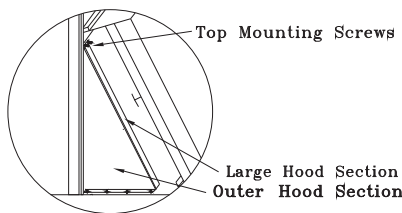

Figure 11. Hood attachment



8. Install the blockoff angle underneath the economizer, as illustrated in [Figure 12](#). The blockoff angle is designed to close the opening created, between the economizer and the base, when the economizer assembly is in its operating position.

- a. Holding the blockoff angle with the holes at the bottom and the bottom angle outward, tilt the top forward and insert it into the opening between the economizer and the unit base.
- b. Press the bottom of the blockoff angle against the unit and line up the holes. Using the provided screws, secure it into place.

Figure 12. Block-off installation

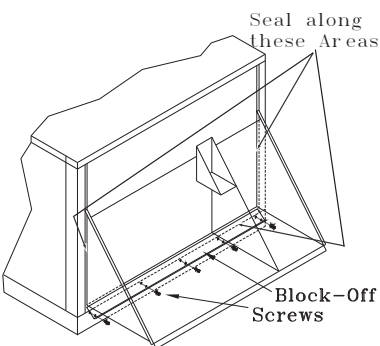

Economizer is shown with the end panel removed for illustration purposes. It is not necessary to remove this panel in the field.

Note: If Options Module (RTOM) is not installed then connect plug PPF5 to J4 on the Refrigeration Module (RTRM) in the control box.

Replace the control box cover and the compressor access panel.

- 17. Install the end panel, removed in [Step 2](#), onto the economizer as follows:
 - a. Bend the top of the end panel, at the crease line, outward to approximately 45 degrees.
 - b. Place the end panel over the economizer and slide the top of the panel under the roof panel. Replace the screws along the top, as illustrated in [Figure 8](#).
 - c. While pushing in at the crease in the end panel, reinstall the two (2) screws along each side above the crease in their original location, as illustrated in [Figure 8](#).
 - d. Align the upper row of three (3) screw holes with the holes in the bottom of the economizer frame, as illustrated in [Figure 8](#).

Note: Do not use the original 5 lower screw holes in the end panel.

18. Using the sealant that shipped with the economizer, seal along each side, bottom, and any other areas that could be a potential air leak, as illustrated in [Figure 8](#).

19. Replace the filter/fan access panel.
20. Complete the setup and checkout procedures in the "Minimum Position Settings" section.

Figure 8. End panel placement

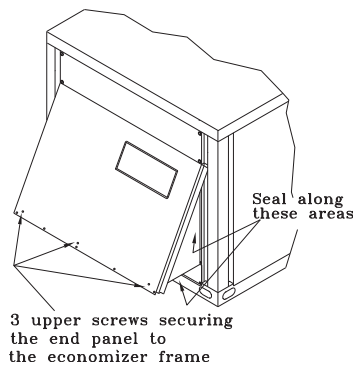

9. Using the sealant that shipped with the economizer, seal along each side, bottom, and any other areas that could be a potential air leak, as illustrated in [Figure 12](#).

10. Replace the filter/fan access panel.

Minimum Position Setting

- 1. To adjust the minimum position setting and check out the economizer, the power must be connected.
- 2. Close the unit disconnect and place the zone sensor fan selector in the fan "ON" position and the heat/cool selector in the "OFF" position. This will place the damper in the minimum ventilation position.
- 3. To adjust the minimum position setting for the required ventilation air, turn the potentiometer (on the ECA) clockwise to "open" (to increase the amount of ventilation) or counterclockwise to "close" (to decrease the amount of ventilation). The damper will open to this setting each time the blower circuit is energized.
- 4. When adjusting minimum position, the damper may move to the new setting in several small steps. Once the damper has remained in position for 10 - 15 seconds without movement, it can be assumed it is at the new position.
- 5. Replace the filter access panel.
- 6. The damper will close when the blower circuit is de-energized.

Dry Bulb Settings

Standard economizer dry bulb changeover is field selectable to 4 outdoor temperatures. See [Table 1](#) for potentiometer settings. The selection is made on the ECA.

Reference Enthalpy Settings

Economizer enthalpy changeover is field selectable to 4 points. See [Table 1](#) for potentiometer settings. The selection is made on the ECA.

Table 1. Potentiometer settings

Potentiometer Setting	Dry Bulb	Enthalpy
A	73°F ^(a) (22.8°C)	27 Btu/lb (63 kJ/kg)
B	70°F (21.1°C)	25 Btu/lb (58 kJ/kg)
C	67°F (19.4°C)	23 Btu/lb (53 kJ/kg)

Factory Installed Economizer

Each economizer ships inside the unit and requires partial assembling and setup. The following steps are illustrated throughout this section. Refer to the illustrations as the steps are performed.

WARNING

Hazardous Voltage w/Capacitors!

Disconnect all electric power, including remote disconnects and discharge all motor start/run capacitors before servicing. Follow proper lockout/tagout procedures to ensure the power cannot be inadvertently energized. Verify with an appropriate voltmeter that all capacitors have discharged. Failure to disconnect power and discharge capacitors before servicing could result in death or serious injury.

- 1. Remove the filter/fan compartment access panel.
- 2. Remove the five (5) or nine (9) lower screws in the end panel. See figure [Figure 9](#). Lay block off angle aside for later installation in [Step 8](#).

Note: Do not remove the three (3) or five (5) screws in the upper row of the end panel.

- 3. Grasp the bottom of the end panel and pull the economizer assembly outward into the operating position, as illustrated with the arrow in [Figure 9](#).

Figure 9. Screw removal and end-panel positioning

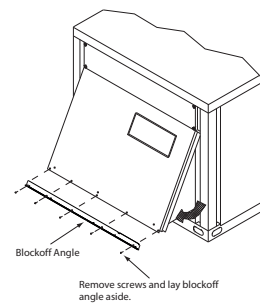

Table 1. Potentiometer settings

Potentiometer Setting	Dry Bulb	Enthalpy
D	63°F (17.2°C)	22 Btu/lb (51 kJ/kg)
E	55°F (12.8°C)	19 Btu/lb (44 kJ/kg)

(a) Factory Setting

Table 2. Economizer control options

Control Option	Enable Conditions ^(a)	Optional Sensors Required ^(b)
Dry Bulb (standard)	See Table 1	None
Reference Enthalpy (ReliaTel Only)	See Table 1	Outdoor Humidity (BAYENTH007A)
Comparative Enthalpy (ReliaTel Only)	Outdoor Air Enthalpy 3.0 BTU/lb. less than Return Air Enthalpy	Outdoor Humidity Return Humidity Return Temperature (BAYENTH008A)

(a) Economizing is enabled when these conditions are met.
(b) Conditions level will be self configured when optional sensors are connected.

Figure 13. End panel

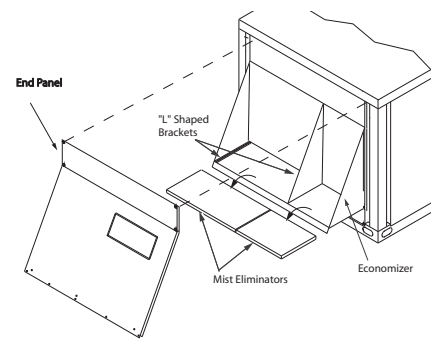

- 4. Remove approximately 3" of gasket material from the bottom of each corner post to expose the holes used to attach the economizer assembly to the unit, as illustrated in [Figure 10](#).
- 5. With the screws provided, secure each side of the economizer assembly by inserting a screw, through the clearance hole in the bottom of the corner post, into the engagement hole in the economizer assembly. Refer to [Figure 10](#).

Figure 10. Gasket removal and clearance holes

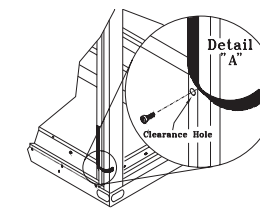

- 6. From inside the evaporator fan compartment, remove the following parts:
 - a. plastic bag containing:
 - i. one tube of sealant
 - ii. screws
 - b. barometric relief hood
- 7. The barometric relief hood ships in two (2) sections and is secured during shipping. Remove shipping screw securing the hood and install it, as follows:
 - a. Attach the larger section of the barometric relief hood to the back of the economizer assembly, using 2 screws at the top and to the drain pan support using 2 screws at the bottom, as illustrated in [Figure 11](#).
 - b. Attach the outer section of the hood to the larger section, previously installed.
 - c. With both sections assembled together, secure the completed hood at the top with two (2) screws provided, as illustrated in [Figure 11](#).

Note: If barometric relief is desired, remove the shipping screw from the barometric relief damper blade and ensure that it swings freely, before attaching the barometric hood.

Mist Eliminator Servicing

It is recommended that the mist eliminators be cleaned or replaced annually. Refer to [Figure 13](#) during the following maintenance procedure.

- 1. Remove screws from end panel that secure it to the unit and economizer.
- 2. Set end panel aside.
- 3. Loosen "L" shaped brackets that secure mist eliminator in place if necessary.
- 4. Remove mist eliminators and clean.
- 5. Replace mist eliminators and adjust "L" shaped brackets to secure and hold mist eliminator in place.
- 6. Replace end panel and secure to unit and economizer.

The manufacturer optimizes the performance of homes and buildings around the world. A business of Ingersoll Rand, the leader in creating and sustaining safe, comfortable and energy efficient environments, the manufacturer offers a broad portfolio of advanced controls and HVAC systems, comprehensive building services, and parts. For more information, visit www.IRco.com.

The manufacturer has a policy of continuous product and product data improvement and reserves the right to change design and specifications without notice